



R.A.T. Rapid Axle Technology

FOCUS

GERMAN ENGINEERED

R.A.T. MANUAL

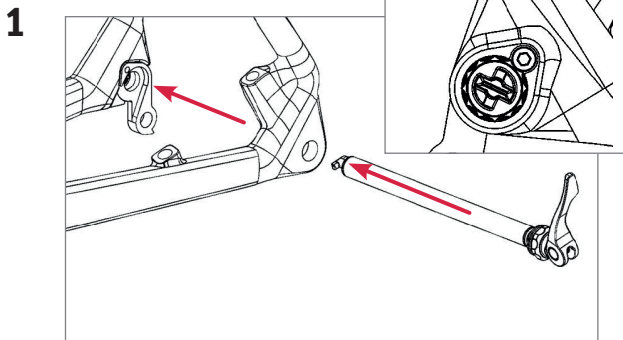
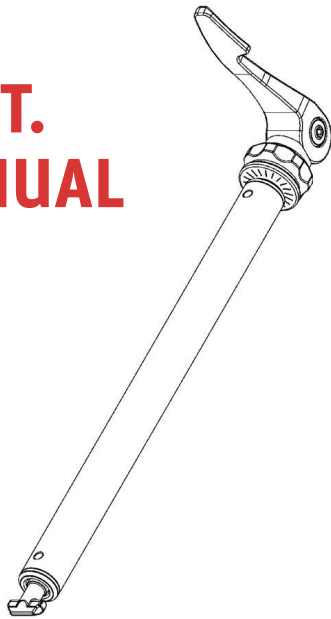

Insert the R.A.T. axle with open lever in the correct position. The T-end of the axle should be aligned with the insert.

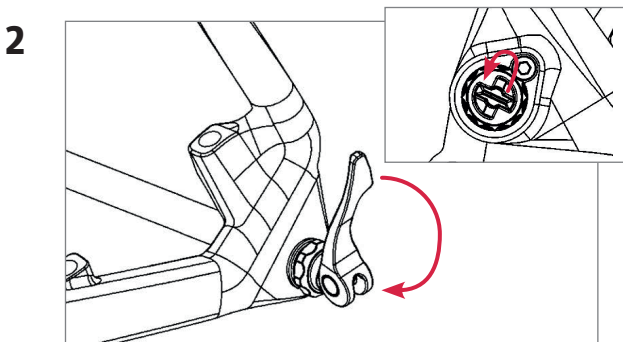

Rotate the axle 90° clockwise till the T-End is stopped by the insert. Never overtighten the axle or use a lot of force to turn it. The axle should rotate easily.

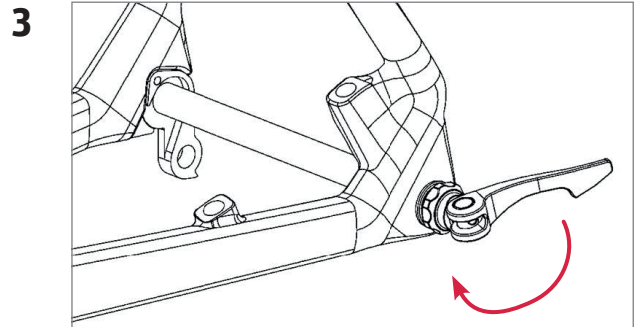

Flip the lever appr. 180° until it stops.

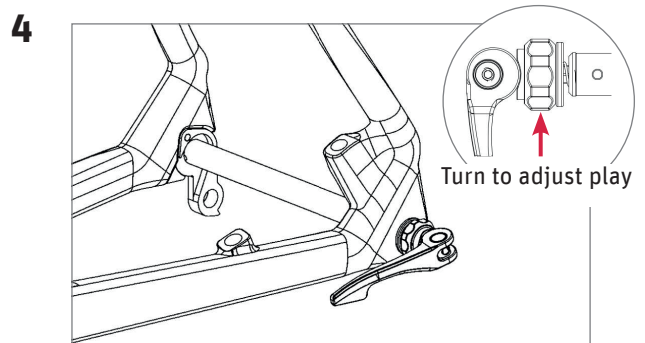

If the lever is clamping to much/less adjust the preload nut until the lever is clamping stoutly.



Incorrect closed lever or low clamping force could result in disengagement of the wheel may result in injuries or death

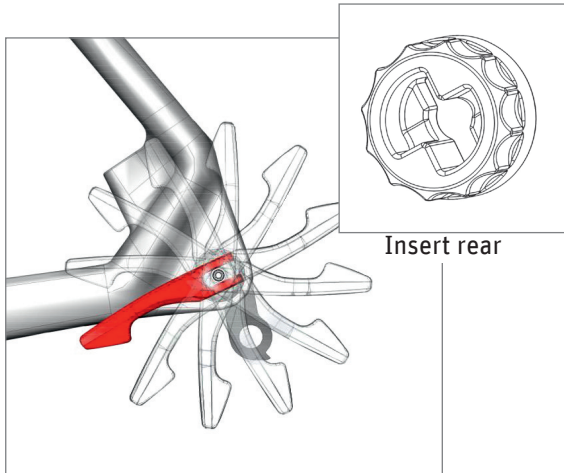

Rear lever position can be adjusted like your personal preference. Just turn the Insert on the drive side in the position you want. Each grooving is changing the position about 30° degree.

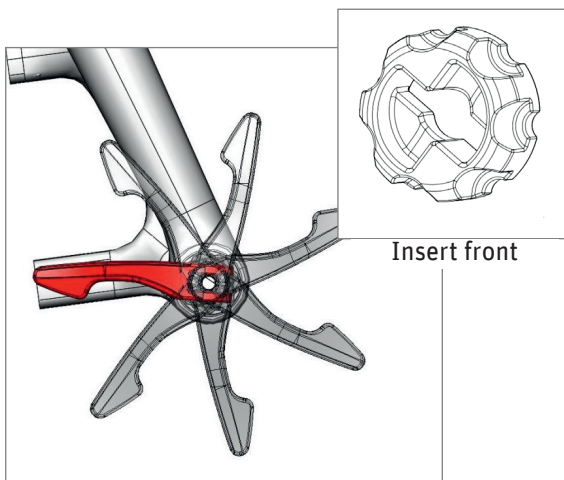

Front lever position can be adjusted as well. The front insert has 7 positions. Each grooving is changing the position about 51,5° degree.

5 Facts about R.A.T. :

- › It's all about alignment!!!
- › brakecaliper and disc rotor must always be in the same position
- › R.A.T. is the only fast thru axle system for road available

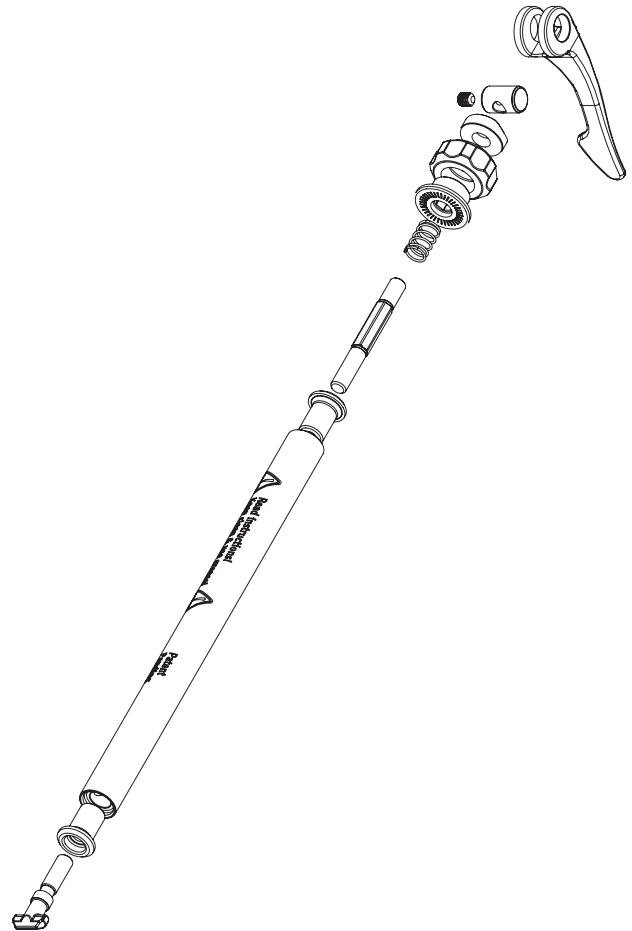

Focus Bikes

Derby Cycle Werke GmbH ● Siemensstraße 1-3 ● D-49661 Cloppenburg
Tel +49.4471.966-0 ● Fax +49.4471.966-44 845 ● Mail info@derby-cycle.com

www.focus-bikes.com